

A dual-core highly programmable 120dB image sensor

B. Dupont, J. Caranana, P.A. Pinoncely, J. Michelot, C. Bouvier, S. Cohet, P. Jourdain, P. Monsinjon, Pyxalis, France.

Abstract

To make High Dynamic Range image sensors easier to integrate in cameras and subsystems, Pyxalis proposes a novel digital architecture, making the management of image acquisition and the reconstruction of HDR images much simpler. This work describes the development and characterization of a 120dB High Dynamic Range sensor based on a novel processor based architecture. Two processors are embedded in the detector to allow flexible shutter operation, windowing, sequencing as well as High Dynamic Range modes. Thanks to built in HDR reconstruction, the image sensor outputs 20bits per pixels based on 14bits column ADCs and two complementary HDR image acquisition methods. The entire image acquisition is fully synchronous.

Introduction

In many fields of applications, noise floor has been the key parameter to choose or develop a new instrument. Especially in astronomy, medical, and space application, the look for the lowest possible noise floor led to the development of interesting technologies such as Electron Multiplied CCDs [1] with noise floor down to 0.3 e- RMS. However such scientific detectors come with several drawbacks. The total number of charges that can be handled by low noise detectors makes it difficult to use in scenes where high contrasts are present, where it is important for instance to achieve low noise in the dark as well as maintaining details in the bright zones of the images. Back in 2011, Fairchild imaging introduced the sCMOS that combined a low noise floor (1e- to 1.28 e- depending on literature) and a full-well larger than 30ke- [2]. The introduction of CMOS in the scientific imaging allows much more flexibility in the handling of high dynamic range data with on board sequencers and ADCs. In this paper we present a new scientific detector, HDPYX dedicated to high contrast imaging applications, such as, for instance, hyper spectral or multi-spectral applications.

High Dynamic range scientific constraints

Although High Dynamic range have become popular in many non-scientific applications, such as surveillance, automotive and more recently movie capture with Dolby Vision or NHK proposal to have HDR in cinemas and in the broadcast industry, Scientific applications have a unique set of requirements when it comes to HDR imaging. First, all the data must be present in one frame. Multiple frame acquisition, as done traditionally in digital photography causes the risk to loose information. Secondly, the user does not know the scene illumination. And finally the linearity is a critical factor. The following table summarizes the different technics uses to create High Dynamic range imaging. In CMOS the most elegant option is certainly the Multiple readout gain, that can be done ideally using multiple conversion factors inside one pixel. This is not be confused with Well adjustment method, in which the user applies multiple resets level to vary the saturation level. In the HDPYX sensor, a multiple gain pixel is combined with an

interleaved integration time to boost the dynamic range up to 120dB

solution	Multiple integration times	Well adjustment	Logarithmic	Multiple readout gain
high luminance	+	+	+	+
low luminance	+	+	-	+
Linearity	Good	Fair	No	Fair to good
CDS	Yes	No	No	Yes
SNR	+	-	--	+
Pixel Complexity	Low-medium	Low	Med	Low
Readout Complexity	Low	Low	Low	High
drawbacks	Several asynch. scene taken, several images to combine. Risk of motion blur, large memory needs	Dispersion of the reset voltage can create artefact in reconstruction, if furtive event occurs during reduced well the signal is partially lost	Low sensitivity at low light levels	Higher area and power consumption

HDPYX architecture

The following diagram shows the overall sensor architecture. One of the unique feature of the HDPYX sensor is that it is a true Dual-Core image sensor, running two 32bits microcontrollers to operate the device.

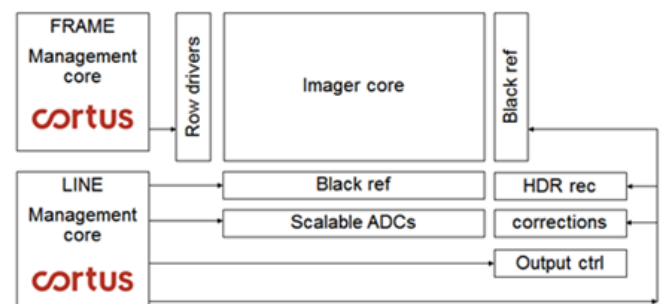

Figure 1: HDPYX Sensor architecture

The frame management core takes care of every aspects linked to the operating mode of the sensor, such as: shutter type, windowing, subsampling, integration time calculation, etc. The line management core takes care of the Black level correction, ADC driving, data formatting and HDR reconstruction. The HDR reconstruction method up to 20bits per pixel is based on two distinct HDR methods. The pixel shown in the figure below allows the HDPYX sensor to capture image linearly up to 90dB

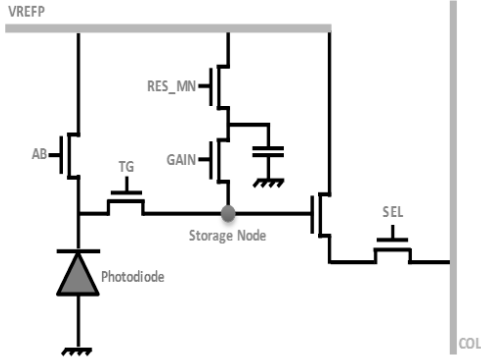

Figure 2 HDPYX pixel

To reach 120dB, the HDPYX sensor uses two different integration times: one for odd lines and one for even lines. Both integration times end at the same moment, with the transfer of the data from the photodiode to the floating diffusions. Due to speed constraint, a dedicated [hardware](#) peripheral was designed at Pyxalis to convert multiple gains (2 gains and 2 integration times) to a full 20bits linear data, as shown on the following diagram.

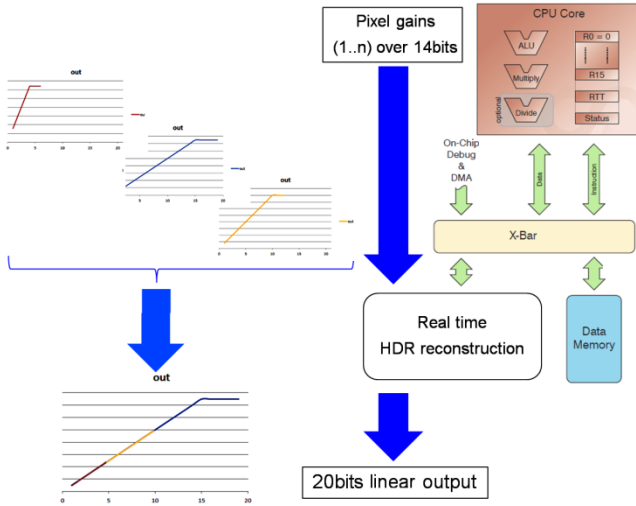

Figure 3 HDPYX HDR reconstruction peripheral principal

Performances

The HDPYX sensor was manufactured in Tower Jazz 180nm technology and characterized at Pyxalis lab. The sensor is fully functional and capable of producing 20bits HDR images:

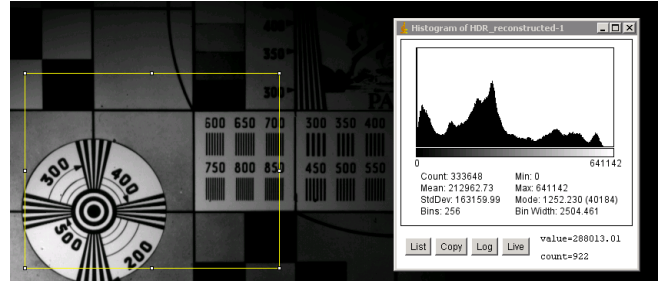

Figure 4: High dynamic range image taken with HDPYX sensor on 20bits output dynamic.

The sensor has been measured down to 2.6e- RMS at room temperature, at nominal frame rate (45 FPS). SNR has been measured as well, showing the positive effect of high gain at low signal.

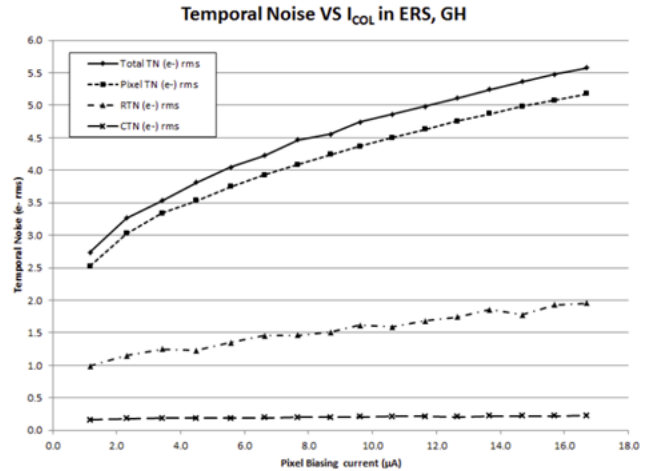

Figure 5: noise floor on the HDPYX sensor is 2.6 e- RMS at room temperature

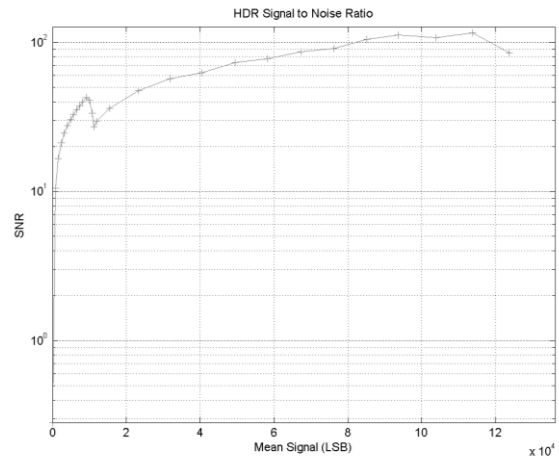

Figure 6: Sensor SNR as a function of signal.

Future Work

Following the successful characterization of the HDPYX sensor, the device will enter in service by the end of 2016 in various scientific instruments in the field of spectrometry and hyperspectral measurements. Designed as a platform, the sensor can also be modified to accommodate other wavelengths such as NIR or deep-UV.

References

- [1] P.Jerram et al. "The LLLCCD: Low light imaging without the need for an intensifier". Proc. SPIE vol.306 pp. 178-186, 2001T.
- [2] B. Fowler et al. "A 5.5Mpixel 100 frames/sec wide dynamic range low noise CMOS image sensor for scientific applications", Proc. SPIE 7536, Sensors, Cameras, and Systems for Industrial/Scientific Applications XI, 753607